



ELIMINATOR **Vortex250**

Ultra-compact filter for powerful magnetic filtration of system debris



To place your order, call your local sales office or order online at www.primaflowandp.co.uk



Bedford 01234 845 600 | Chorley 01257 238 100 | Poole 01202 733 510 | Wakefield 01924 288 700

Sentinel Eliminator Vortex[®]250 is the perfect ultra-compact filter solution to protect the heating system where space is restricted.

Why use Eliminator Vortex250?

Fast installation

- Easily installed above or below the boiler.
- 360° rotational T-piece allows flexibility in fitting.

Simple servicing

- Isolate using the integrated valve, remove the magnet, and then the drain cap to flush clean.
- With no extra headroom required, the filter allows a straightforward flush no matter where it's installed.

Confidence

- 10 year total product guarantee.
- Dual seals are pressure tested on every single unit.
- Collects both magnetic and non-magnetic types of damaging debris.

Ultra-compact and easy to fit

Save time on site with the Eliminator Vortex250, which is easily sited above or below a boiler.

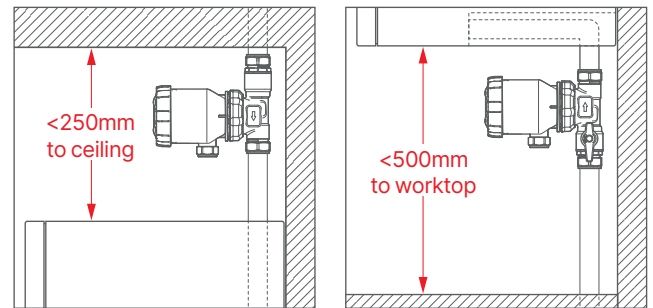

In-line installation and a 360° rotational T-piece allows flexibility in fitting.

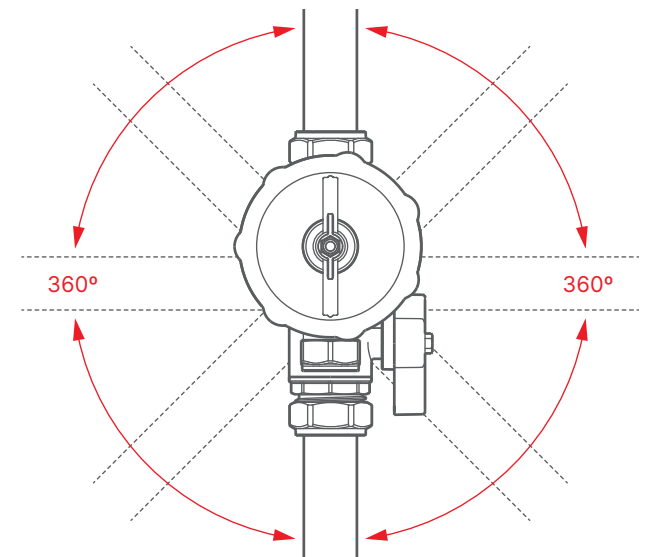

Use Eliminator Vortex250 as part of The Sentinel System best practice approach to water treatment:



Clean
X800 Cleaner



Protect
X100 Inhibitor



Maintain
X100 Quick Test

To place your order, call your local sales office or order online at www.primaflowfandp.co.uk



Bedford **01234 845 600** Chorley **01257 238 100** Poole **01202 733 510** Wakefield **01924 288 700**

WE SIMPLY DELIVER MORE

Premium protection and performance

Powerful magnetic filtration

The combination of magnets, totalling 9000 Gauss, makes the Eliminator Vortex250 the most powerful ultra-compact filter on the market.

Reliable quality

High quality dual seals and valves, a 10 year total product guarantee, and low maintenance costs provide peace of mind.

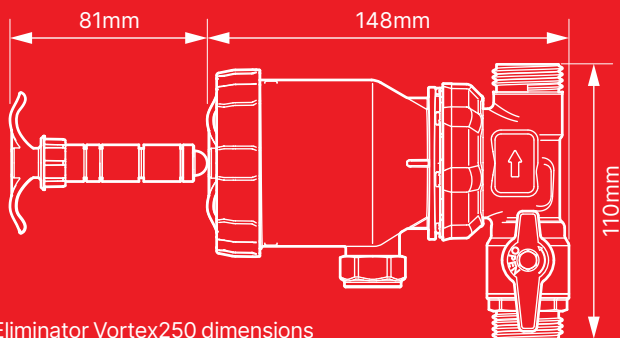

Eliminator Vortex250 dimensions

Secure drain cap

Simple servicing via the drain cap means there are no seals to replace, preventing the risk of leaks.

Integrated isolation valve

With isolation built in to the T-piece, there's no additional valves to install or leak points to check.

To place your order, call your local sales office or order online at www.primaflowfandp.co.uk



Bedford **01234 845 600**

Chorley **01257 238 100**

Poole **01202 733 510**

Wakefield **01924 288 700**

Amendments to...
PART L

WHAT'S NEW?

BS7593 (the 'Code of practice for the preparation, commissioning and maintenance of domestic central heating and cooling water systems') is being incorporated into Part L of the Building Regulations. This amendment transforms BS7593 from an advisory document to one that is now mandated – its points must now be adhered to.

THE MAIN CHANGES

1. Installation of in-line filter required

A filter to protect system components now needs to be installed, complementing a chemical clean and flush. Sentinel filters like the Vortex300 and Vortex500, or Vortex250, can be used.



2. Annual checks for concentration of chemicals and water cleanliness

Keep on top of inhibitor levels! The presence of inhibitor to protect systems must be checked each year. We offer simple and easy tests like the X100 QuickTest, which allows confirmation of inhibitor presence within minutes.



3. Inhibitor to be re-dosed at 5 year intervals

Whilst X100 will give lifetime protection, the amendments state that a system should be cleaned, fully drained and refreshed every 5 years, adding new inhibitor.



4. Biocidal and frost protection to be used where applicable

Across low temperature installations, fungal growth is to be kept at bay using a biocide like X700 and for systems liable to freezing, an inhibited antifreeze, such as X500, needs to be used.



5. There are only 3 recommended cleaning methodologies:

- **Powerflushing** (external pump and tank)
- **Mains pressure**
- **Gravity cleaning**

Ensure your powerflush is compliant. An 'external pump and tank arrangement' is required, otherwise the procedure does not meet the criteria, for example flushing using magnet technology, does not fit the bill. A powerflushing machine like the JetFlush Rapid is the perfect machine to tick all of the boxes for any powerflushing job.



www.sentinelprotects.com



To place your order, call your local sales office or order online at www.primaflowandp.co.uk



Bedford 01234 845 600 | Chorley 01257 238 100 | Poole 01202 733 510 | Wakefield 01924 288 700